



SEL-2506 Rack-Mount Remote I/O Module

Simple Teleprotection and Remote I/O



*Simple installation, simple setup,
simple diagnostics.*

Features and Benefits

■ Protection and Monitoring

Improve security of pilot communications for existing two- and three-terminal line applications. Use local or remote trip and close coil monitoring capability. Implement simple bus protection using contact inputs and outputs from existing relays.

■ Integration

Expand the I/O of SEL relays that are MIRRORED BITS® communications compatible. Make I/O status from any relay available to SEL MIRRORED BITS communications schemes. Use with an SEL-2100 Logic Processor for high-speed control applications.

■ Safety

Replace control wiring to outside cabinets with fiber-optic cable to eliminate paths for dangerous voltages. All wiring is behind the panel.

■ Dependability and Reliability

Add the high reliability and security of MIRRORED BITS communications to your installations. Use the communications monitoring feature to alarm when fiber-optic control cabling has been damaged, disturbed, or altered.

■ Status Indication

Print user-configurable labels to clearly indicate I/O usage.

■ Easy Application and Installation

Set parameters with switches. Quickly install and remove using patented Screw-Terminal Connectorized® blocks, without disturbing wiring.

Teleprotection Application

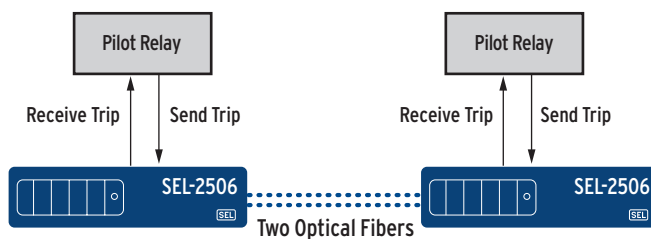

MIRRORED BITS® communications using two optical fibers.

Making Electric Power Safer, More Reliable, and More Economical®

SEL-2506 Rack-Mount Remote I/O Module

Functional Overview

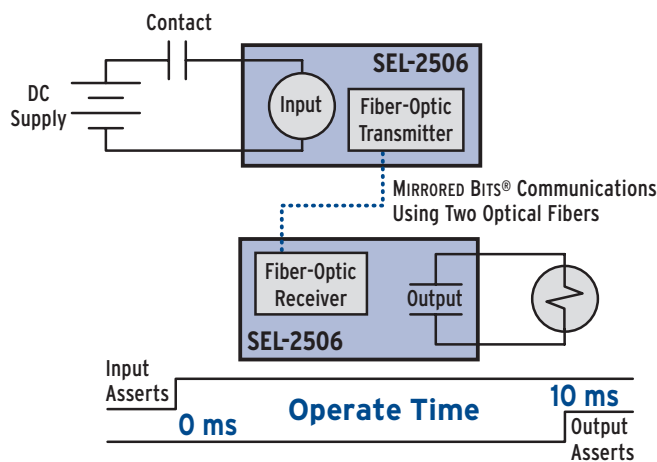

Operate Time

Data Rate (bps)	Standard Outputs	High-Speed Outputs
38400	10 ms	4 ms
19200	12 ms	6 ms
9600	18 ms	12 ms

Digital Output Ratings

	Standard	High Speed
Make	30 A	30 A
Carry @ 70°C	6 A	6 A
Pickup Time	<5 ms	<200 μs
MOV Protection	270 Vac rms	dc only
Continuous	360 Vdc	330 Vdc
Break L/R=40 ms	0.3 A @ 125 Vdc	10 A

Digital Input Ratings

4 mA nominal input current

Voltage Range	On	Off
24 Vdc	15–30 Vdc	
48 Vdc	38.4–60 Vdc	<28.8 Vdc
110 Vdc	88–132 Vdc	<66 Vdc
125 Vdc	105–150 Vdc	<75 Vdc
220 Vdc	176–264 Vdc	<132 Vdc
250 Vdc	210–300 Vdc	<150 Vdc

Operating Temperature Range

–40° to +85°C (–40° to +185°F)

Power Supply Ratings

48/125 V	36–200 Vdc or 85–140 Vac, 5 W max.
125/250 V	85–350 Vdc or 85–264 Vac, 5 W max.

Dimensions

Two rack units

88.9 mm H x 482.6 mm W x 236.2 mm D (3.5 in x 19 in x 9.3 in)

Application Overview

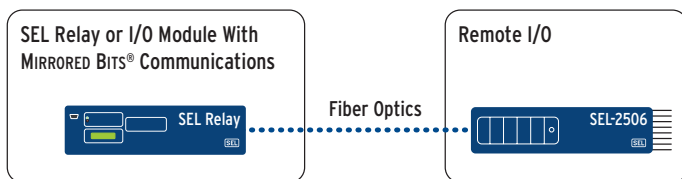

The SEL-2506 communicates with a remote device using MIRRORED BITS communications. Each contact input controls one of the eight transmit bits, while each of the eight receive bits controls an output contact. Use the transmitted contact input status for control and indication at the remote device. Use the remote device to control the SEL-2506 output contacts in trip, close, and other schemes. Use two optical fibers instead of 32 large-diameter wires, saving material and labor costs.

General Specifications

Communications Port Options

Connector	Optical Fiber	Compatible Transceiver	Maximum Recommended Distance (km)
V-System®	200 μm multimode	SEL-2800	0.5
ST®	50, 62.5, or 200 μm multimode	SEL-2815	15
ST	9, 10 μm single-mode	SEL-2829	23
ST	9, 10 μm single-mode	SEL-2830	80
ST	9, 10 μm single-mode	SEL-2831	110
9-Pin D	NA: EIA-232 wire*	NA	0.015

* Wire recommended only within same cabinet



Pullman, Washington USA
Tel: +1.509.332.1890 • Fax: +1.509.332.7990 • www.selinc.com • info@selinc.com

© 2007 by Schweitzer Engineering Laboratories, Inc. PF00066 • 20071023

