



## SEL-551C Overcurrent/Reclosing Relay

# Distribution Protection and Control



*Comprehensive overcurrent protection, multiple-shot reclosing, and optional front and rear communications in one compact relay.*

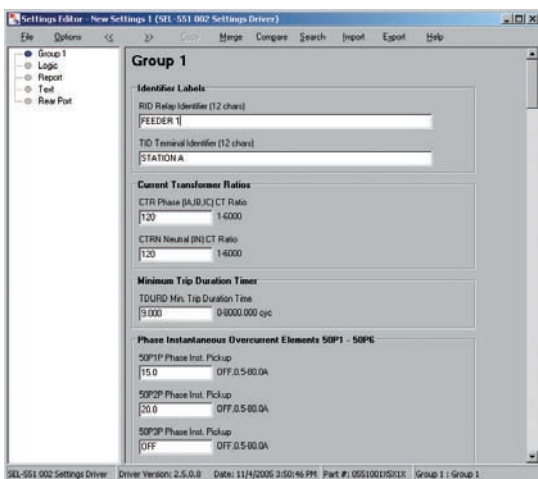

Develop settings using acSELEATOR® QuickSet™ SEL-5030 Software.

## Features and Benefits

### ■ Complete Overcurrent Protection

Protect lines and equipment using a sensitive and secure mix of phase, negative-sequence, and ground overcurrent elements. Get high-speed operation, even with severe CT saturation, using the SEL Adaptive Overcurrent Element.

### ■ Multiple-Shot Reclosing With Sequence Coordination

Program up to a four-shot reclose sequence with reclose initiate supervision, skip-shot sequencing, and stall-open interval timing.

### ■ Integration

Integrate into industrial protection and control schemes with Modbus® RTU protocol. Order the rear serial communications port as either EIA-232 or EIA-485. Optional front EIA-232 port allows easy connection, even while communicating on the rear port.

### ■ Field-Proven With Robust I/O

Program the six inputs and three outputs to meet your application needs using SELogic® control equations. A wide operating temperature range (-40° to +85°C) allows for installation in a control house or outdoor enclosure.

### ■ Advanced Programmable Logic and Local/Remote Controls

Use acSELEATOR® QuickSet™ SEL-5030 Software to configure traditional or advanced protection and control schemes. Quickly make logic changes or improvements, including edge triggers or latches within SELogic control equations for advanced control. Use the front panel or serial port to actuate separate control switches.

**Making Electric Power Safer, More Reliable, and More Economical®**

## Functional Overview

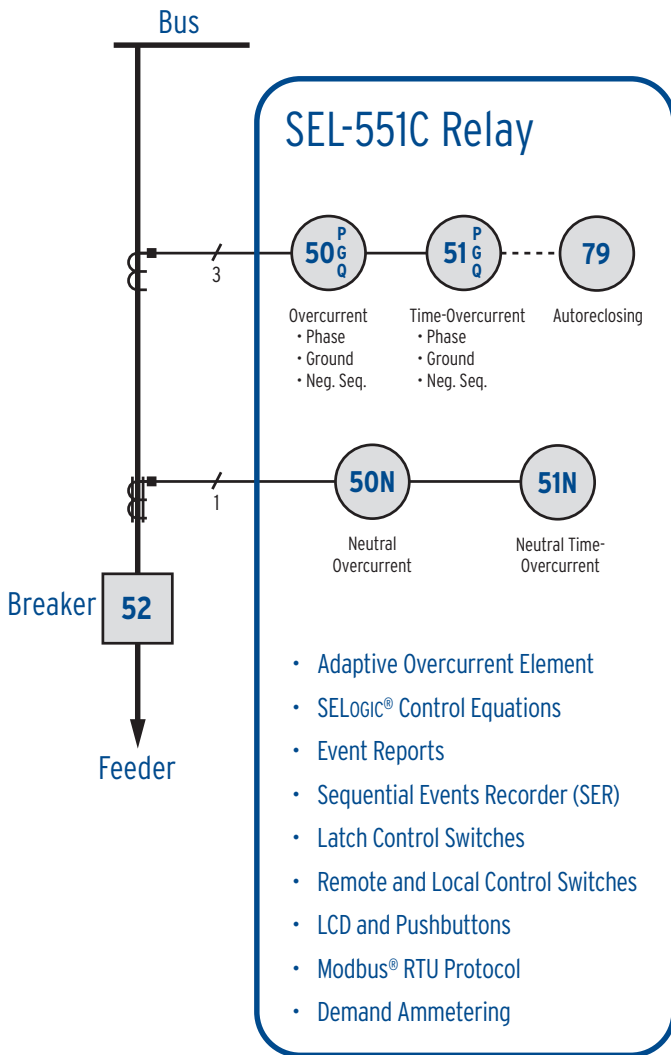

## SEL-551C Highlights

### SEL-551C Relay

The SEL-551C includes all of the features of the SEL-551, plus the following:

- Optional front EIA-232 serial communications port
- Digital I/O mix with six inputs and three outputs
- Eight programmable latch control switches
- Programmable alarm contact

### Overcurrent Elements

- Numerous instantaneous-overcurrent elements
- Two time-overcurrent elements of each type: phase, ground, and negative sequence
- Demand current thresholds alarm for overload and unbalance

### Latch Control Switches

Use latch control switches in the SEL-551C for various applications:

- Reclosing relay enable/disable
- Ground relay enable/disable
- Sequence coordination enable/disable
- Latching output contacts

The SEL-551C provides eight latch control switches.

### Programmable Autoreclosing

The SEL-551C can autoreclose a circuit breaker up to four times before lockout. Use SELogic control equations to perform a number of these reclosing functions:

- Initiate reclosing for a particular trip operation
- Drive to lockout immediately from a control operation, external signaling, or high-current trip
- Skip to the next reclose shot when an overcurrent element picks up
- Block reset timing to prevent repetitive trip-reclose cycling
- Program sequence coordination to keep the relay in step with downstream reclosers to prevent trip overreaching

### SELogic Control Equations

Assign the relay inputs to suit your application, logically combine selected relay elements for various control functions, and assign output relays to your logic functions.

- Design unique trip, reclose, and control schemes
- Replace expensive external timers, auxiliary relays, and their associated wiring and panel space
- Provide local status and control with custom labels on the front LCD
- Program SELogic control equations using rising or falling edge triggers

## Windows®-Based Graphical User Interface

- Save engineering time while keeping flexibility. Communicate with the SEL-551C Overcurrent/Reclosing Relay through any ASCII terminal, or use the acSELEATOR QuickSet Software graphical user interface.
- Develop settings offline with a menu-driven interface and completely documented help screens. Speed installation by copying existing settings files and modifying application-specific items.
- Simplify the setting procedure with rules-based architecture to automatically check interrelated settings. The software highlights out-of-range or conflicting settings for correction.
- Transfer settings files using a PC communications link with the SEL-551C.

## Typical Installation

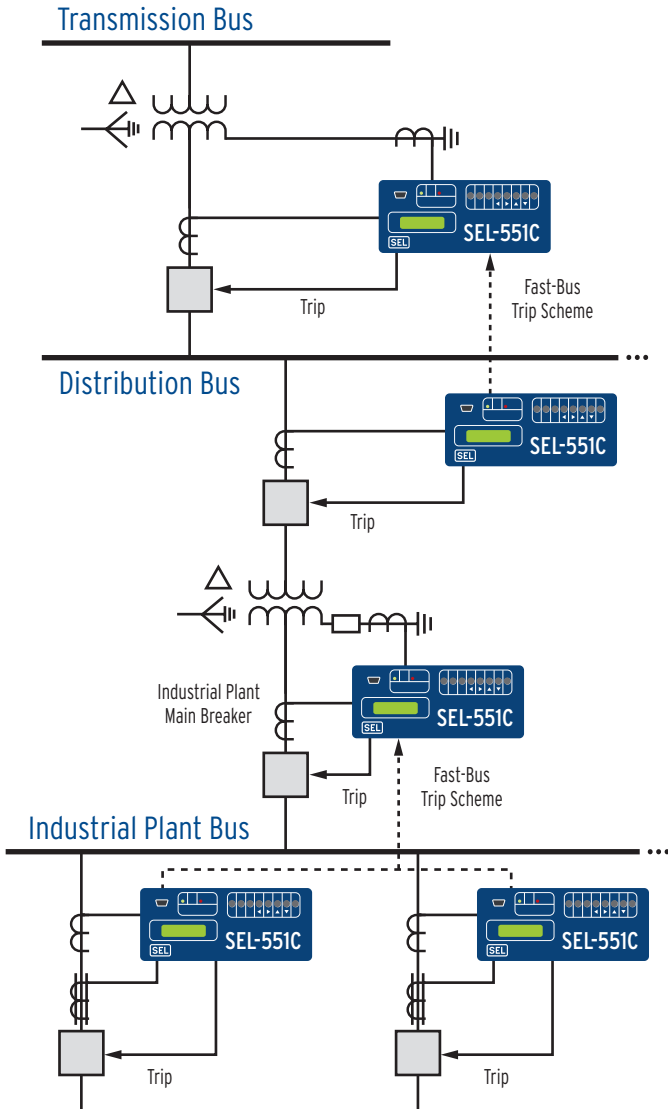

Apply SEL-551C Relays throughout the power system.

## Front and Rear View

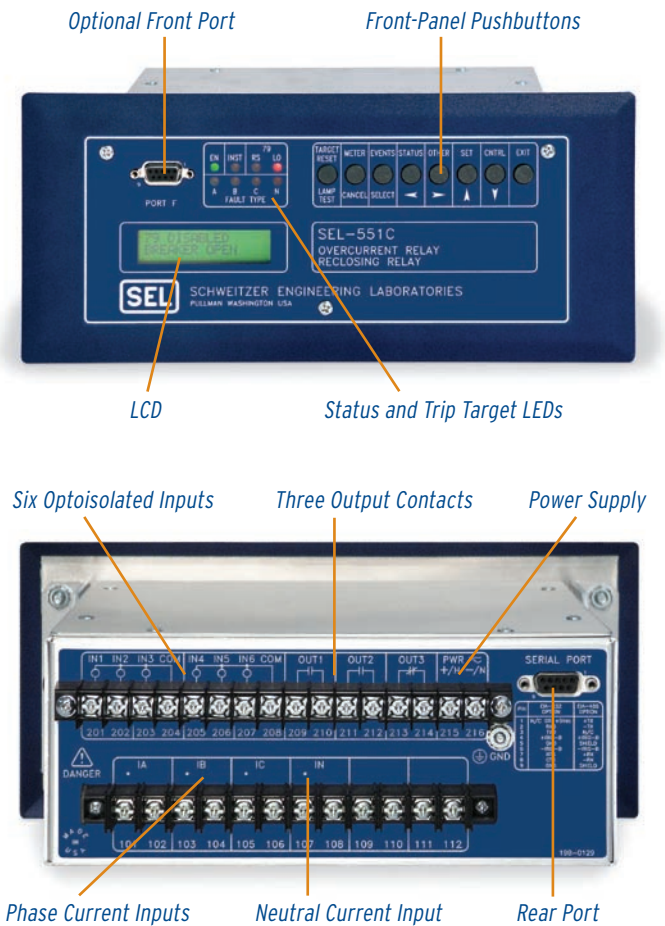

### SEL Terminal Adapter

The SEL Terminal Adapter (C675) is included when ordering the SEL-551C with the EIA-485 rear port option. The terminal adapter with the quick connector makes connecting EIA-485 communications fast and easy.

## Applications

- Protect distribution feeders, distribution buses, transformers, capacitors, and circuit breakers.
- Select the "fast bus" trip scheme when protecting a distribution or industrial plant bus.
- Choose "fast" or "slow" curve operation to allow for cold-load pickup.
- Connect the separate neutral current input to accommodate core-balance current transformers, separate neutral current transformers, tertiary winding current transformers, or CT ground residual circuits.
- Easily connect to existing Modbus systems using the Modbus RTU rear-port configuration and the 9-pin connector to the terminal adapter included with the EIA-485 option.
- Get accurate tripping, even during high-fault conditions and severe CT saturation, using the SEL Adaptive Overcurrent Element.
- Coordinate with downstream protection using instantaneous-overcurrent and time-overcurrent elements, and multiple-shot reclosing.

# SEL-551C Overcurrent/Reclosing Relay

## General Specifications

### AC Current Inputs

#### 5 A nominal

15 A continuous, 500 A for 1 second, linear to 100 A symmetrical

Burden 0.16 VA @ 5 A; 1.15 VA @ 15 A

#### 1 A nominal

3 A continuous, 100 A for 1 second, linear to 20 A symmetrical

Burden 0.06 VA @ 1 A; 0.18 VA @ 3 A

### Optoisolated Input Ratings

#### Level Sensitive

48 Vdc On for 38.4–60 Vdc; off below 28.8 Vdc

125 Vdc On for 105–150 Vdc; off below 75 Vdc

220 Vdc On for 176–264 Vdc; off below 132 Vdc

250 Vdc On for 200–300 Vdc; off below 150 Vdc

#### Non-Level Sensitive

24 Vdc On for 15–30 Vdc

### Instantaneous-Overcurrent Element Specifications

#### Pickup Accuracy

5 A nominal  $\pm 0.10$  A secondary and  $\pm 5\%$  of setting

1 A nominal  $\pm 0.02$  A secondary and  $\pm 5\%$  of setting

Transient Overreach <5% of pickup

### Time-Overcurrent Element Specifications

#### Pickup Accuracy

5 A nominal  $\pm 0.10$  A secondary and  $\pm 5\%$  of setting

1 A nominal  $\pm 0.02$  A secondary and  $\pm 5\%$  of setting

Curve Timing Accuracy  $\pm 1.5$  cycles and  $\pm 4\%$  of curve time for currents between (and including) 2 and 30 multiples of pickup

### Serial Communications

9-Pin Sub-D Connector

Terminal Adapter C675 for EIA-485 connection

Speed 300, 1200, 2400, 4800, 9600, 19200, 38400 bps

### Protocols

ASCII

Distributed Port Switch Protocol (LMD)

Modbus RTU

### Power Supply Ratings

125/250 Vdc or Vac 85–350 Vdc or 85–264 Vac

48/125 Vdc or Vac 36–200 Vdc or 85–140 Vac

24 Vdc 16–36 Vdc polarity dependent

### Operating Temperature

IEC performance rating of  $-40^{\circ}$  to  $+85^{\circ}\text{C}$  ( $-40^{\circ}$  to  $+185^{\circ}\text{F}$ )

## Adaptive Overcurrent Element

The SEL-551C phase instantaneous-overcurrent elements normally operate using the output of a cosine filter algorithm. During heavy fault currents, when the relay detects severe CT saturation, the overcurrent elements operate on the adaptive current algorithm.

Based on the level of a "harmonic distortion index," the adaptive current is either the output of the cosine filter or the output of the bipolar peak detector. The SEL-551C can detect severe CT saturation and automatically decide which filter provides the fastest operating time.

The cosine filter provides excellent performance in removing dc offset and harmonics. However, the bipolar peak detector has the best performance in situations of severe CT saturation when the cosine filter magnitude estimation is significantly degraded. Combining the two filters provides an elegant solution for ensuring dependable phase instantaneous-overcurrent element operation.



Pullman, Washington USA  
Tel: +1.509.332.1890 • Fax: +1.509.332.7990 • www.selinc.com • info@selinc.com

© 2005, 2007 by Schweitzer Engineering Laboratories, Inc. PF00109 • 20071227

