



## SEL-749M Motor Relay

# Increase Productivity and Reduce Down Time With Economical Motor Protection and Control



*Use the SEL-749M to protect and control all types of three-phase motors, including two-speed and reduced-voltage start motors.*

### Features and Benefits

- **True Temperature-Based Thermal Overload Protection**  
Eliminate false tripping, especially during cyclic overload operations. Release motor capability unavailable with traditional overload relays.
- **Comprehensive Start Reports and Trends**  
Track motor performance during the critical starting period with complete motor start reports and 30-day average motor start trending. Only SEL offers this valuable tool for tracking motor performance.
- **Option Cards for Added Functionality**  
Customize the relay for your particular protection and control applications. Select optional voltage, I/O, and communications cards.
- **Complete Reporting for Increased Operating Time**  
Troubleshoot motor/process problems using valuable, stored information about motors and processes from motor statistics, oscillograms, event reports, and sequential events records.
- **Extensive Communications and Software Capabilities**  
Communicate seamlessly with built-in SEL ASCII and optional Modbus and DeviceNet protocols. Quickly and easily set the SEL-749M with the included, Windows®-based acSELERATOR® SEL-5030 Software.
- **Compact, Ruggedized Hardware**  
Mount in any motor control center with this UL/IEC switchgear-rated, short-mounting-depth relay.

Motor photo courtesy of Rockwell Automation

***Making Electric Power Safer, More Reliable, and More Economical®***

# SEL-749M Motor Relay

## Functional Overview

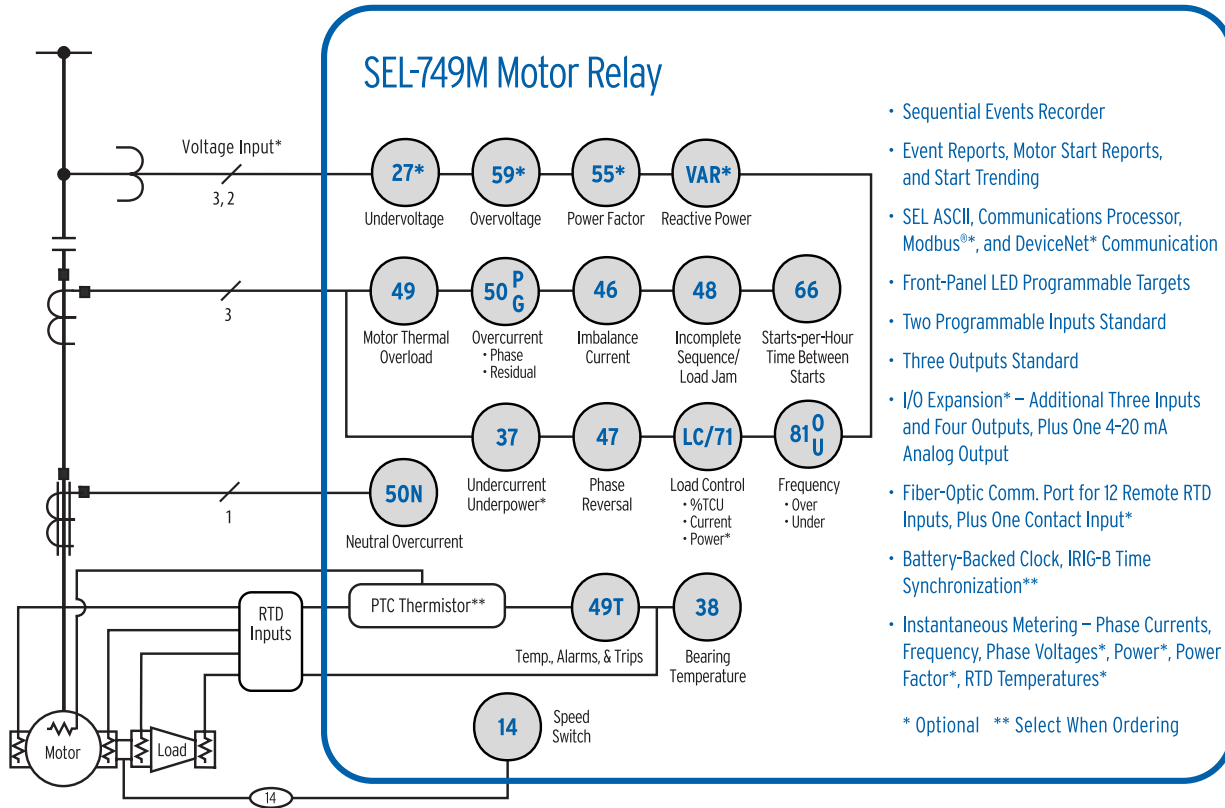

## Applications

Choose the SEL-749M Motor Relay for all three-phase motor protection and control installations. In addition to standard applications, the relay can also protect motors in two specialized applications: reduced-voltage starting and two-speed processes.

### Reduced-Voltage Start Motors

Protect motors that use soft-start starting profiles to avoid high-current surges in the electrical system, high starting torque, and system mechanical stress on the motor. In addition, the SEL-749M protects the motor during voltage and current spikes caused by conventional wye-delta starters and other reduced-voltage starting techniques.

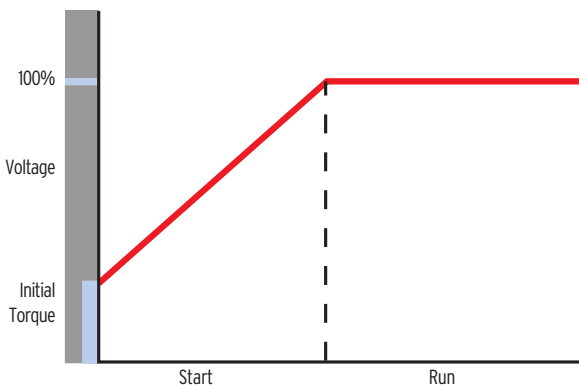

Use reduced voltage starting for less motor stress.

### Two-Speed Motor Protection

Use SEL-749M settings to select a second value for the rated FLA motor current, CT input ratio, and thermal overload protection via a digital control input. Two-speed applications include designed two-speed processes (blowers), briefly increased motor loading, or maximizing loading for ambient temperature excursions (e.g., day/night loading on exposed water pumps or conveyor belts). The SEL-749M protects two-speed motors in all of these applications.

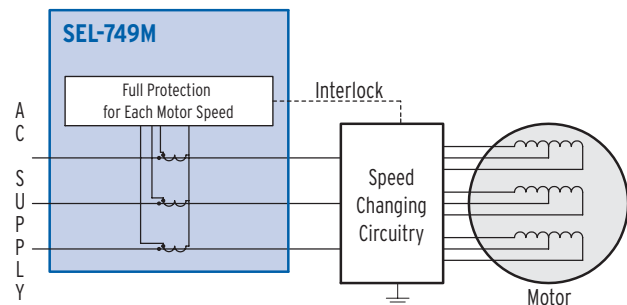

Protect two-speed motors with the SEL-749M.

## Motor Protection

### Motor Thermal Overload Protection

The SEL-749M provides locked rotor, running overload, and negative-sequence current imbalance protection using a patented thermal overload model. The relay accurately tracks the heating effects of load current and imbalance current while the motor is starting and running. You can choose two easy setting methods:

- Motor nameplate ratings
- Overload limit curves

For simple, effective protection, enter the motor nameplate ratings for Full Load Current, Locked Rotor Current, Hot Stall Limit (Locked Rotor) Time, and Motor Service Factor. Cooling Time and Thermal Capacity Reset Level are also incorporated in the SEL-749M thermal overload protection. Alternately, select the appropriate thermal overload limit curve from 45 standard curves.

Optional external RTD monitoring inputs extend thermal overload protection to include direct temperature measurement for tripping or thermal overload model biasing to protect motor windings as well as motor and load bearings.

### Thermal Overload Model Elements

The SEL-749M thermal overload model replicates motor heating and cooling characteristics according to applied motor current, using a Starting (or Locked Rotor) element and a Running element. In the Starting element, the thermal overload model provides locked rotor protection using the  $I^2t$  threshold represented by the rated locked rotor current and locked rotor time. The relay compares this threshold to measured  $I^2t$ . The Running element provides overload and imbalance protection by using current to calculate motor temperature in real time, and comparing this temperature to predetermined thresholds. The relay trips if operating conditions exceed these settings.

### Tracking Motor Temperature

The excellent motor temperature tracking capability of the SEL thermal overload model is demonstrated on motor cyclic overloads. Motor applications such as crushers and chippers can routinely and cyclically overload normal motor operating ratings. These cyclic overloads cause an ordinary overcurrent-based thermal model relay to false trip, causing unnecessary manufacturing process down time. Test data comparing actual motor measurements and the SEL thermal model show how the SEL-749M thermal overload model accurately tracks motor heating (measured by RTD temperature) on a cyclic overload.

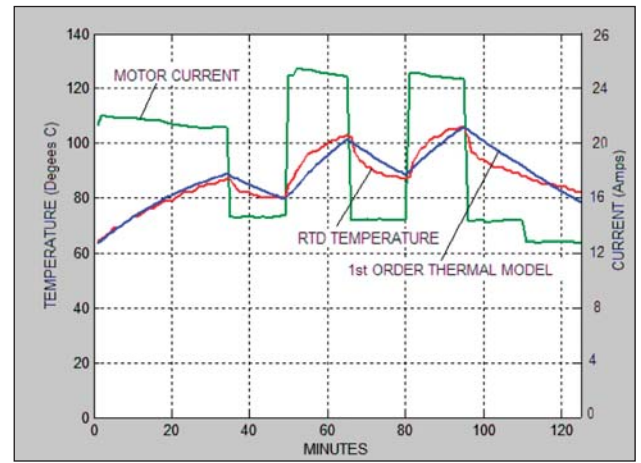

*SEL thermal model accurately tracks motor temperature.*

### Thermal Overload Model—Best-In-Class Cyclic Overload Protection

Cyclic overload testing was performed on the SEL-749M and on another brand of digital motor relay that uses a time-overcurrent-based thermal model. A primary-current test generator provided signals to both relays to supply a cyclic overload current with a 1.0 per unit rms value, which does not overheat the motor. The SEL-749M completed the full test without tripping. However, the other relay

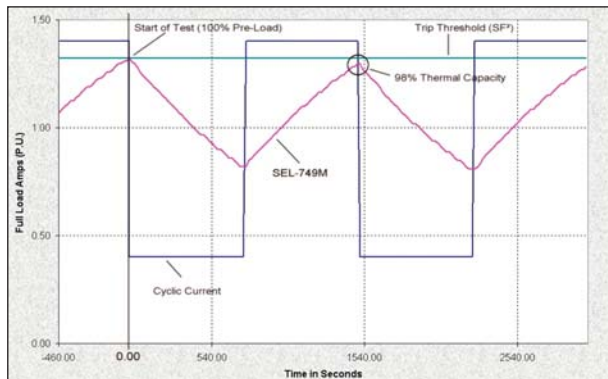

*SEL-749M Motor Relay proper operation.*

prematurely tripped during the second overload because the overcurrent-based thermal model quickly ratchets the calculated motor temperature up to the trip point. Avoiding this situation for the overcurrent-based thermal model relay requires reducing the motor cooling time setting, which results in inefficient and possibly damaging trial and error attempts. With the SEL-749M thermal overload model rating method, there is no guessing; set the motor time constants from the motor manufacturer's specifications.

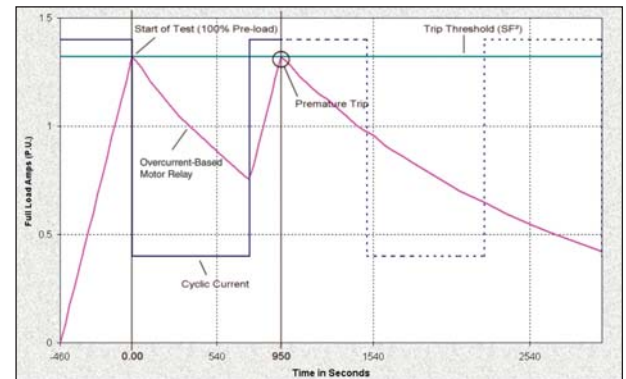

*Overcurrent-based motor relay false trip.*

## Motor Protection

### Short-Circuit Tripping

Phase, residual, and neutral/ground overcurrent elements detect cable and motor short-circuit faults. The SEL-749M includes:

- Two phase-overcurrent elements
- Two residual-overcurrent elements
- Two neutral-/ground-overcurrent elements

Set the relay to trip instantaneously or with a definite-time delay for short-circuit conditions. In the phase-overcurrent elements, the SEL Adaptive Overcurrent Element detects CT saturation and responds with faster operation.

### Load-Loss, Load-Jam, and Frequent-Starting Protection

The SEL-749M detects load-loss (undercurrent) and load-jam conditions. Load-jam protection trips the motor quickly to prevent overheating from stall conditions. The SEL-749M provides frequent starting protection using settable starts-per-hour and time-between-starts protection functions. The relay stores motor starting and thermal overload data in nonvolatile memory to prevent motor damage caused by frequent starts.

### Imbalance Current and Phase-Reversal Protection

The SEL-749M provides an imbalance current element that trips in the event of a motor single-phasing condition or for heavy current imbalance. The relay phase-reversal protection detects the motor phase rotation and trips after a time delay if the phase rotation is incorrect. The SEL-749M provides this protection even when phase voltages are not available.

### Voltage-Based Protection Elements

The SEL-749M offers optional voltage inputs for open-delta or four-wire wye connections for additional protection and monitoring:

- Over- and undervoltage
- Underpower
- Over- and underfrequency
- Reactive power
- (voltage-based)
- Power factor

## Metering and Monitoring Capabilities

### Current- and Voltage-Based Metering Functions

The SEL-749M provides accurate metering for input currents, optional voltages, and temperature measurement for optional RTDs. View frequency and phase, neutral, residual, and imbalance current magnitudes. When equipped with voltage inputs, the relay provides additional meter quantities, such as phase and residual voltage; real, reactive, and apparent power (kW, kVAR, kVA); and power factor. When you select RTD inputs, the relay reports temperature and location of each RTD.

Use front-panel menus, serial port commands, and the optional Modbus® or DeviceNet protocols to view metering values.

## Analog Output

The SEL-749M has an optional 4-20 mA analog output for a remote panel meter or plant distributed control system input. Program the analog output to provide important operation information:

- Full load current
- Winding/bearing temperature
- Average/max phase current
- Average power consumed
- Percent thermal capacity
- Power factor

## Motor Operation Maintenance Tools

### Motor Operating Statistics

Reduce costs by scheduling preventive maintenance using relay data:

- Time running and stopped
- Average and peak current, voltage, %TCU
- Number of emergency starts
- Protection element alarms/trips
- Motor-running percent

### Motor Start Report

The SEL-749M provides an unmatched view of motor performance during the critical starting cycle. Every time the protected motor starts, the relay stores a start report detailing motor currents, optional voltages, and thermal capacity used to start.

In addition, the relay calculates the starting time in seconds and records the maximum current magnitude and minimum voltage magnitude during the start. You can customize the report sample rate and length to record as much as 60 seconds of motor start data. The relay stores the five latest start reports in nonvolatile memory.

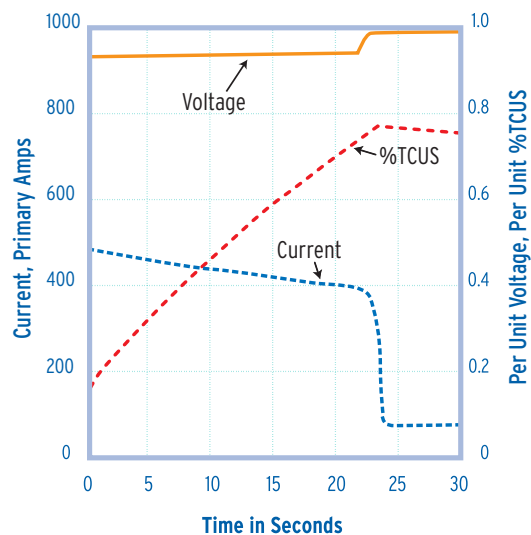

Motor start report data exported to a plotting program.

### Motor Start Trending Report

Monitor starting trends with the motor trend report. The relay maintains the 18 most recent 30-day averages of motor start report data in nonvolatile memory. Use actual start performance data to check for out-of-tolerance motor starting, and perform preventive maintenance before an unplanned failure occurs.

## Windows-Based Graphical User Interface

### Use acSELEATOR to Set the SEL-749M Relay

- Save engineering time while keeping flexibility. Communicate with the SEL-749M through any ASCII terminal, or use the acSELEATOR SEL-5030 Software graphical user interface.
- Develop settings offline with a menu-driven interface and completely documented help screens. Speed installation by copying existing settings files and modifying application-specific items. Interface supports Windows operating systems.
- Simplify the settings procedure with rules-based architecture to automatically check interrelated settings. Out-of-range or conflicting settings are highlighted for correction.
- Transfer settings files by using a PC communications link with the SEL-749M Relay.

### Use acSELEATOR to Analyze Fault Records and Relay Element Response

- Convert relay event reports to oscillograms with time-coordinated element assertion and phasor/sequence element diagrams.
- Quickly analyze fault records and relay element response using the acSELEATOR event viewer.

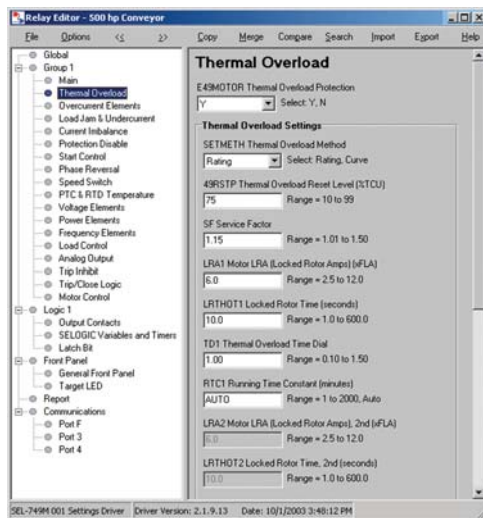

acSELEATOR SEL-5030 Software simplifies settings and saves engineering time.

### SEL-5031 acSELEATOR Designer

Use SEL-5031 acSELEATOR Designer (optional at an extra charge) to create custom views of settings, called Application Designs, to reduce complexity, decrease the chance of errors, and increase productivity:

- Lock and hide unused settings.
- Lock settings to match your standard for protection, I/O assignment, communication, and SELogic® control equations.
- Enforce settings limits narrower than the device settings.
- Define input variables based on the equipment nameplate or manufacturer's terminology or scaling and calculate settings from these "friendlier" inputs.
- Use settings comments to guide users and explain design reasoning.

## Fault Reporting

### Sequential Events Recorder (SER)

The SEL-749M tracks the pickup and dropout of protection elements, control inputs, and contact outputs. The date and time of each transition are available in a Sequential Events Recorder (SER) report. This chronological report helps you determine the order and cause of events and assists in troubleshooting.

### Event Summaries and Event Reports

The SEL-749M captures a 15-cycle or a 64-cycle length event report and creates an event summary each time the relay trips in response to programmable conditions. View the summary using the front-panel LCD or by connecting to a computer. Event summaries contain useful data about relay trips:

- Event number, date, and time
- Trip type
- Magnitudes of the phase, neutral, and residual currents
- Magnitudes of the phase-to-phase or phase-to-neutral voltages

The relay saves the most recent event reports and event summaries in nonvolatile memory, so the information is retained even if relay power is removed.

Full-length event reports contain the event summary data, plus 15 or 64 cycles of detailed current, voltage, and protection element data, as well as input and output data.

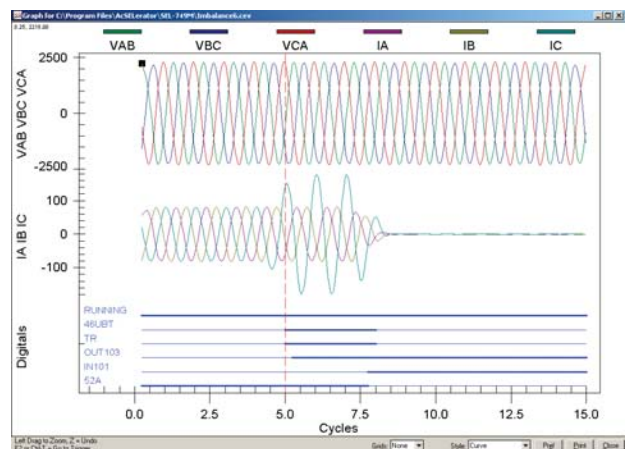

Event report oscillogram shows current imbalance.

### Front-Panel Targets and Messages

Program front-panel targets to indicate any relay element operation, and modify front-panel labeling via a customizable slide-in card. Extra cards and a word processor template are available.

The relay automatically determines the trip type and displays this information on the front-panel display. Trip type messages reveal motor operating conditions that tripped the relay:

- Thermal and locked rotor
- Load loss and load jam
- Imbalance current
- Phase and ground fault
- Voltage or frequency

# SEL-749M Wiring Diagram

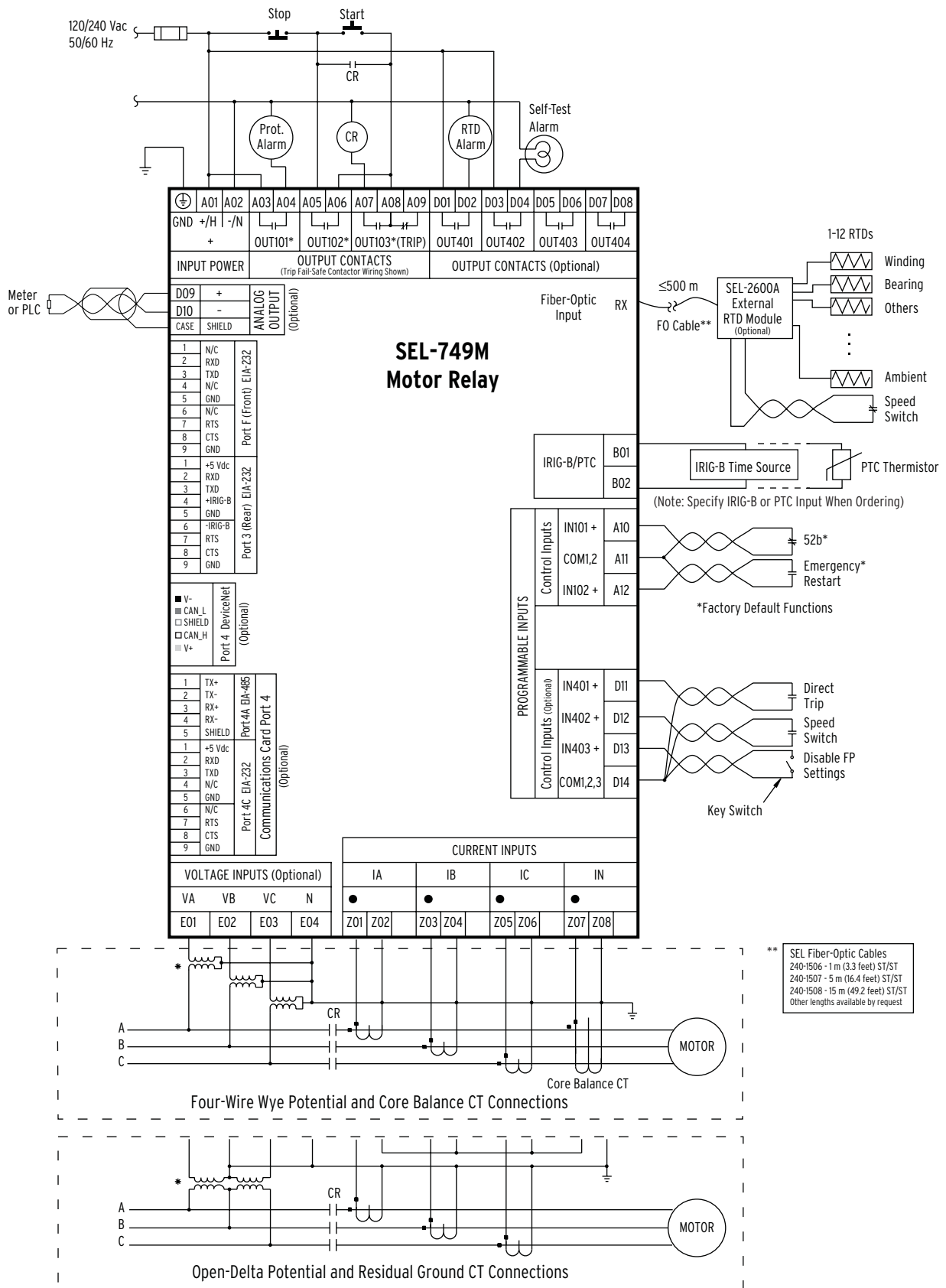

## Flexible Design With Application-Specific Options

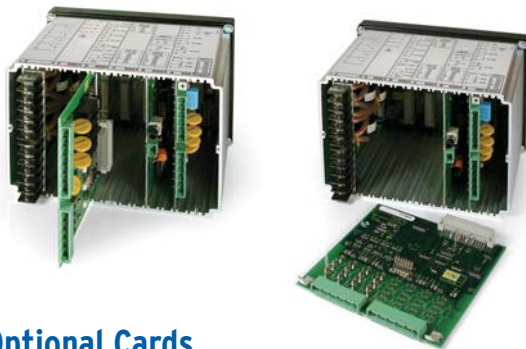

### Optional Cards

#### Communications Protocol Cards

Modbus RTU protocol or SEL ASCII via the EIA-485/EIA-232 communications port.

DeviceNet communications card.

#### I/O Expansion Card

Four additional outputs, three additional inputs, and one 4-20 mA analog output. Control input voltages of 24, 48, 110, 120, 220, and 250 Vac/Vdc.

#### Voltage Inputs Card

Three-phase voltages for voltage, power, and power factor protection and measurement.

## Standard and Optional Protection Features

ANSI	Standard Protection Features
49	Thermal Overload
37	Undercurrent (Load Loss)
46	Current Imbalance and Phase Loss
48	Load Jam, Incomplete Sequence
50P	Short Circuit
50G	Ground Fault
50N	Ground Fault Neutral (Uses Core Balance CT)
	Motor Starting/Running
	Protection Inhibit
	Start Motor Timer
66	Notching or Jogging Device
	TCU (Thermal Capacity Utilization) Start Inhibit
	Anti-Backspin Timer
	Emergency Start
	Two-Speed Protection
19	Reduced Voltage Starting
14	Stall-Speed Switch
81	Frequency (Current-Based)
ANSI	Optional Protection Features
49T	PTC (Positive Temperature Coefficient) Thermistor Overtemperature
	Voltage-Based Protection
27	Undervoltage
59	Overvoltage
37	Underpower
	Reactive Overpower
47	Phase Reversal
55	Power Factor
81	Frequency (Voltage-Based)
49T/38	RTD-Based Protection (as many as 12 RTD inputs with separate Trip and Alarm settings for each RTD)

# SEL-749M Physical Dimensions and Front View

## Dimensions

### CHASSIS

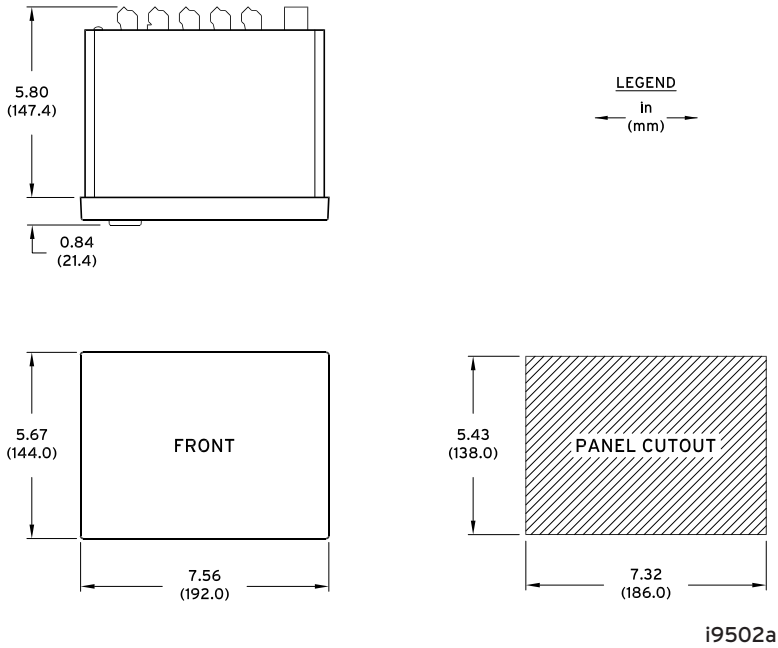

## Front View

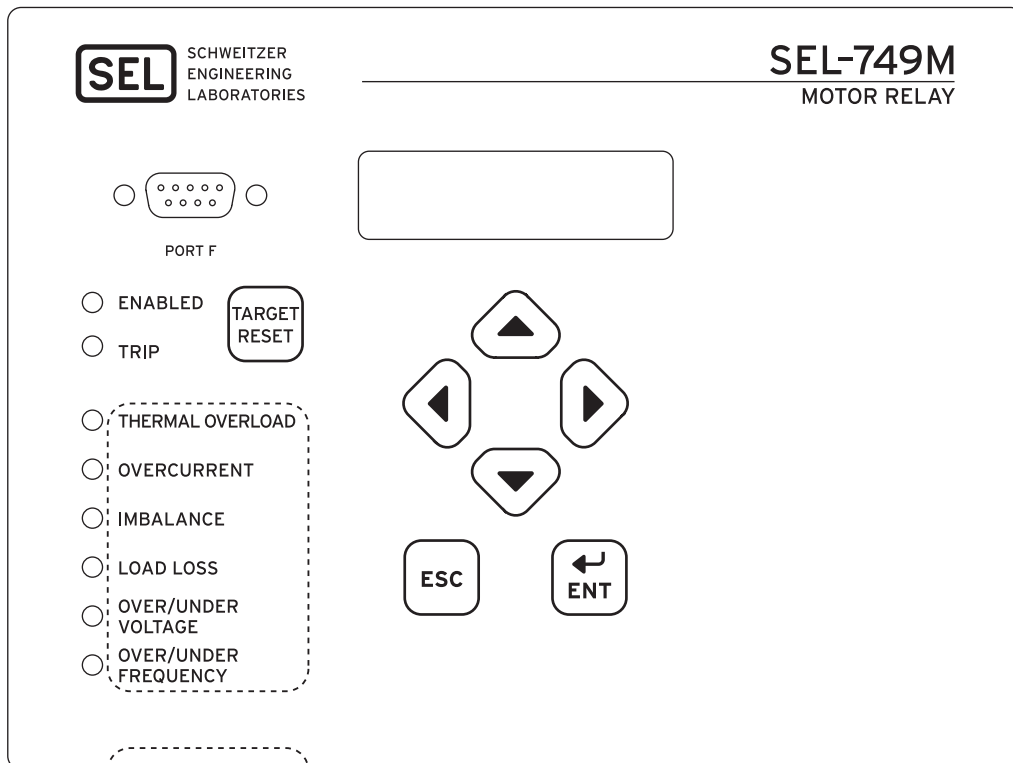

i3662b

# SEL-749M Top and Rear Views

## Top View

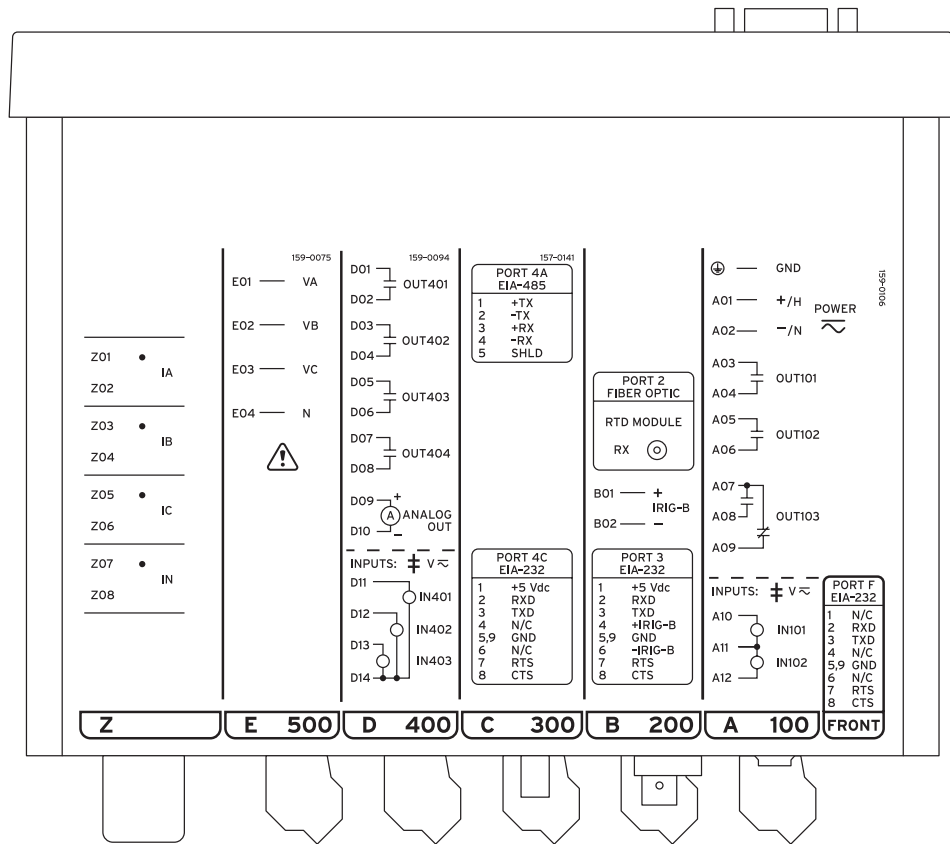

i3710a

⊕ Control Input Voltages (choose one): 24, 48, 110, 120, 220, and 250 Vac/Vdc

## Rear View Wire Terminal Legend

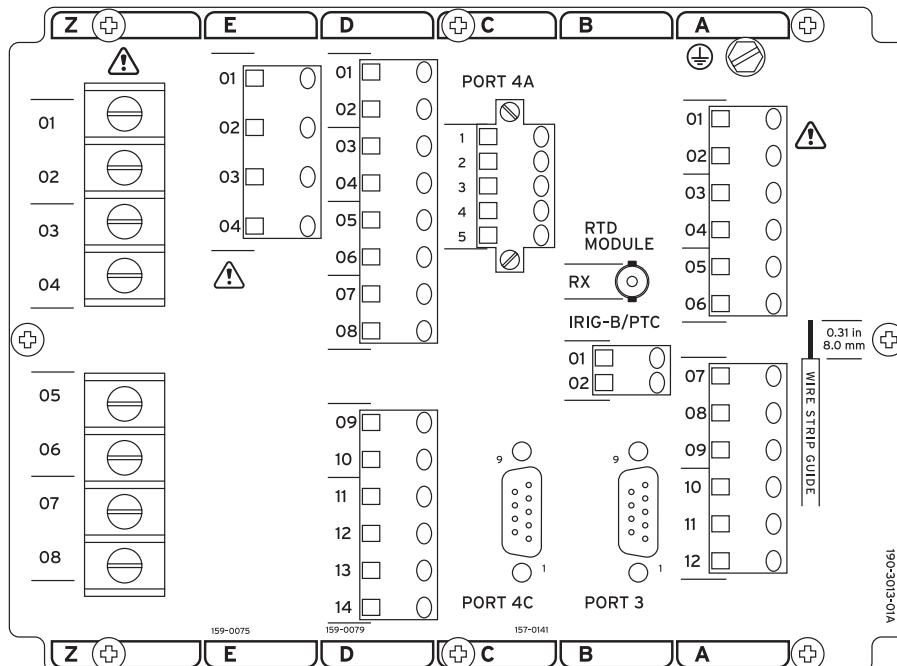

i3664c

## SEL-2600A RTD Module

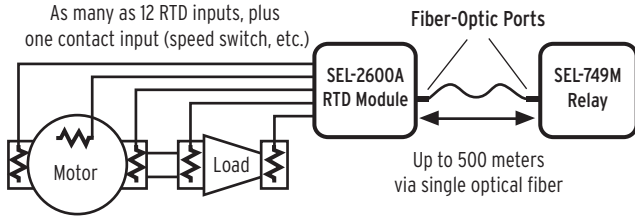

Combining the SEL-749M with the SEL-2600A RTD Module adds temperature trips and alarms, thermal overload element and RTD biasing, RTD open or short alarms, and temperature measurement. Configure each RTD input to use any of four sensor types (Pt100, Ni100, Ni120, or Cu10). Relay settings also define the sensor locations: Motor Windings, Motor or Load Bearings, Ambient Air, and Other for uncategorized applications.

The optional SEL-2600A RTD Module is a resistance temperature device (RTD) module that monitors as many as 12 RTDs and a single contact at the motor. This remote device sends data to the relay through a tough, flexible optical fiber that is routed back to the Motor Control Center, providing complete electrical isolation between the RTDs and the relay. The external module improves measuring accuracy by shortening RTD lead runs, reducing both lead resistance and electrical noise.



## Dimensions

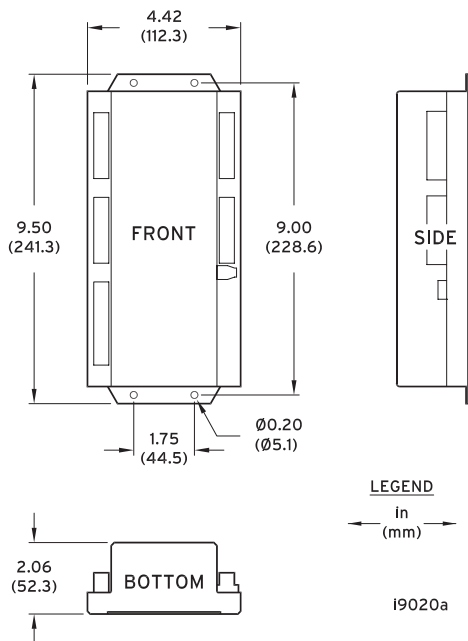

For detailed information, including specifications, see [www.selinc.com](http://www.selinc.com) or [www.selindustrial.com](http://www.selindustrial.com).

## SEL-749M Guideform Specification

### Motor protection shall be provided by a microprocessor-based relay equipped with the following protection functions

- Motor thermal overload model (49): use phase- and negative-sequence current heating to calculate motor temperature during starting and running states; settable motor-stopped cooling time constant
- Phase, neutral, and residual overcurrent elements (50P/50N/50G)
- Imbalance current (46)
- Phase reversal (47)
- Load jam (48)
- Starts per hour (66)
- Over- and underfrequency (81)
- Load loss (undercurrent) (37)
- Antibackspin protection
- Minimum time between starts (66)

### When voltage inputs are specified, the relay shall provide the following protection elements

- Over- and undervoltage (59/27)
- Reactive power (VAR)
- Voltage-based over- and underfrequency (81)
- Underpower (37)
- Power factor (55)

### External temperature capabilities shall offer the following

- Availability of as many as 12 RTD inputs in an external module, which when included, shall have the following features:
  - Optical fiber transmission of RTD temperatures to relay: range > 400 m
  - Separately field-selected RTD types: Pt100, Ni100, Ni120, or Cu10
  - Noise immunity  $\geq 1.0 \text{ Vac}_{\text{peak}}$  at  $f \geq 50 \text{ Hz}$
  - One contact input
- RTD inputs to the motor relay shall support the following:
  - Thermal overload model biasing
  - Temperature alarms and trips (49T/38)
  - RTD open- or short-circuit indication
- Capability of one PTC (positive temperature coefficient) thermistor input (49T)

### Monitoring and reporting functions shall include the following

- Motor start reports: currents and thermal calculation at a programmable rate for as much as the first 60 seconds of the motor start
- Motor start trends: starting time, maximum current, and maximum thermal calculation averages for each of the past 18 months
- Motor operating statistics: starts, time-running, peak/average, and counters
- Fault summaries: fault type and trip data
- Event reports: 15 or 64 cycles of data with 16-samples/cycle resolution
- Sequential events recorder (SER): 512 input, output, and element transitions
- Data stored in nonvolatile, flash memory

### Communications/integration support shall include the following

- ASCII, Modbus RTU, and DeviceNet protocols
- One front-panel and one rear-panel EIA-232 port
- Capability for an additional rear-panel EIA-232 or EIA-485 port
- Windows-based PC software for settings and retrieving reports
- Programmable front-panel target indicators with configurable labels

### Hardware features shall offer the following

- Operating temperature range of  $-40^{\circ}$  to  $+85^{\circ}\text{C}$
- Power supply input operating voltage range of 110–250 Vdc ( $-20\%$  to  $+10\%$ ) or 110–240 Vac ( $-20\%$  to  $+10\%$ ), or 24/48 Vdc or Vac rating
- Demodulated IRIG-B time synchronization input capability
- 4–20 mA analog output capability with kW and power factor
- Relay front panel shall meet the requirements of NEMA12/IP65

# General Specifications

## Standard Relay Features & Functions

### Phase Current Inputs

Nominal Current, $I_{nom}$	1 A or 5 A
Range	0.02-19.2 A • $I_{nom}$
Burden	<1.00 VA @ 5 A <0.10 VA @ 1 A
Continuous	3 • $I_{nom}$
Saturation Current	20 • $I_{nom}$
1 Second Thermal	50 • $I_{nom}$
Measuring Error	±5%, ±0.01 • $I_{nom}$

### Neutral/Ground Current Input

Nominal Current, $I_{Nnom}$	1 A or 5 A
Range	0.01-2.000 • $I_{Nnom}$
Burden	0.28 VA @ 5 A 0.19 VA @ 1 A
Continuous	0.3 • $I_{Nnom}$
1 Second Thermal	5.0 • $I_{Nnom}$
Measuring Error	±5%, ±0.01 • $I_{Nnom}$

### Motor Thermal Overload Model

Locked Rotor Time	1.0-600.0 s
Locked Rotor Current	2.5-12.0 • FLA
Service Factor	1.01-1.50
Setting Methods	
Nameplate ratings	
45 standard curve shapes	
Pickup Error	±1%, ±0.01 • $I_{nom}$
Timing Error	±2% ±15 ms
Independent Stopped/Running cooling rates	
Thermal data retained through relay power cycle	

### Phase Overcurrent Elements

Alarm and Trip Setting Range	4.00-12.00 • FLA
Time Delays	0.00-5.00 s

### Residual Overcurrent Elements

Alarm and Trip Setting Range	0.10-1.00 • FLA
Alarm Time Delay	0.0-120.0 s
Trip Time Delay	0.00-5.00 s

### Neutral/Ground Overcurrent Elements

Alarm and Trip Setting Range	0.01-25.00 A
Alarm Time Delay	0.00-120.0 s
Trip Time Delay	0.00-5.00 s

### Current Imbalance Elements

Alarm and Trip Setting Range	5%-80%
Time Delays	0-120 s
Error	±1%

### Load-Loss (Undercurrent)/Load-Jam Function

Load-Loss Alarm and Trip	
Setting Range	0.10-1.00 • FLA
Time Delays	0.0-120.0 s
Load-Jam Alarm and Trip	
Setting Range	1.00-6.00 • FLA
Time Delays	0-120 s

### Starts Per Hour, Time Between Starts

Max. Starts/Hour	1-15 starts
Min. Time Between Starts	1-150 minutes
Start data retained through relay power cycle	

### Phase Reversal Tripping

Phase reversal tripping based on current or optional voltage inputs

### Load Control

Current Pickup Range	
Lower	Off, 0.20-2.00 • FLA
Upper	Off, 0.20-2.00 • FLA
Power Pickup Range	
Lower	Off, 1-25000 kW
Upper	Off, 1-25000 kW
TCU Pickup Range	
Lower	Off, 1-99 %TCU
Upper	Off, 1-99 %TCU

### Meter Accuracy

Accuracies specified at 20°C and at nominal system frequency unless otherwise noted.	
Current Metering	±2%, ±2°
Optional Voltage Metering	±2%, ±1°
Optional Power Metering	±5% @ PF 0.10-1.00
Optional Power Factor Metering	±2%
Frequency Metering	±0.1 Hz from 44-66 Hz

## Analog Output (optional)

Single Analog Current Output	4-20 mA
Max Load	8 k or 400 ohms
Error	±0.5%, Full Scale
Select From	
FLA, % Thermal Capacity, Hottest Winding RTD, Hottest Bearing	
RTD, Avg. Phase Current, Max. Phase Current, Power, Power Factor	

## Optoisolated Control Inputs

2 Control Inputs, 3 optional for a total of 5 Control Inputs  
Programmable Function

## Contact Outputs

1 Programmable TRIP, 2 programmable auxiliary outputs, 4 optional for a total of 7 Contact Outputs

## Contact Output Temperature Derating

Recommended control output current ratings for UL/CSA requirements

Temperature, T	Maximum Current, I	Maximum On Time	Duty Factor
T <= 60°C	5 A, all outputs	Continuous	Continuous
60°C < T <= 80°C	One at 5 A; others at 2.5 A	Continuous	Continuous
80°C < T <= 85°C	One at 5 A; others at 2.5 A	10 minutes	<15%

## IRIG-B Time Synchronization

Input	Demodulated IRIG-B time code
'1' State	$V_{in} \geq 2.2 V$
'0' State	$V_{in} \leq 0.8 V$
Input Impedance	2 kΩ

## Communications Ports

Front-Panel EIA-232 Port	300-38400 bps
ASCII text communication	
Rear-Panel Modbus EIA-485 port (optional)	300-19200 bps
DeviceNet (optional)	125, 250, 500 kbps

## Optional Features & Functions

### Nominal Voltage Setting

$V_{nom}$	100-30000 $V_{set}$
-----------	---------------------

### Phase Voltage Inputs

Nominal Voltage	0-300 Vac
Four-Wire Wye or Open-Delta	
Burden	<2 VA at 300 V
Measuring Error	±1%, ±0.2 V

### Undervoltage Elements

Alarm and Trip Setting Range	0.60-1.00 • $V_{nom}$
Time Delays	0-120 s

### Overvoltage Elements

Alarm and Trip Setting Range	1.00-1.20 • $V_{nom}$
Time Delays	0-120 s

### Power Factor Element

Alarm and Trip Setting Range	0.05-0.99 PF, Lead/Lag
Time Delays	0-240 s
Measuring Error	±4%

### Reactive Power Element

Alarm and Trip Setting Range	1-25000 kVAR
Time Delays	0-240 s
Measuring Error	±2%

### Underpower Element

Alarm and Trip Setting Range	1-25000 kW
Time Delays	0-240 s
Measuring Error	±2%

### Over- and Underfrequency Elements

Two Alarm and Trip Setting Ranges	45-55 Hz or 55-65 Hz
Time Delays	0.0-240.0 s
Error	±0.1 Hz

### RTD Temperatures

Alarm and Trip Setting Range	1-250°C
Error	±2°C
Open and Short Circuit Detection	
Trip Voting	
Thermal Model Biasing	
RTD Temperature Biasing	

### Optional External RTD Module

12 Remote RTD Inputs  
Monitor Winding, Bearing, Ambient, or Other Temperatures  
PT100, Ni100, Ni120, and Cu10 RTD-types supported, field selectable  
Up to 500 m using fiber-optic cable  
Adds one remote Contact Input (internally wetted)

## Reporting Functions

### Event Summaries/Event Reports

Summaries and 15- or 64-cycle raw and filtered oscillographic records  
Resolution 4 or 16 samples/cycle

### Sequential Events Records

512 latest time-tagged events

## Ratings

### Operating Temperature Range

-40 to +85°C  
-40 to +185°F  
LCD contrast impaired for temperatures below -20°C (-4°F)

### Power Supply Voltage Range

125 Vdc or Vac, 250 Vdc or Vac  
110-250 Vdc (-20% to +10%)  
110-240 Vac (-20% to +10%) 45-65 Hz  
<40 VA total burden  
24 Vdc or Vac, 48 Vdc or Vac  
Interruptions 50 ms @ 125 Vac/Vdc  
100 ms @ 250 Vac/Vdc

## Type Tests

### Electromechanical Compatibility (EMC)

Conducted and Radiated Emissions EN55011 (1998) Class A Group 1

### Electromechanical Compatibility Immunity

Radio Frequency Immunity IEC 61000-4-3 (2002), 10 V/m  
ANSI/IEEE C37.90.2 (1995), 35 V/m  
IEC 61000-4-2 (2001), Levels 1, 2, 3, 4  
8 kV contact discharge  
15 kV air discharge  
IEC 61000-4-4 (2001), 4 kV @ 2.5 kHz and 2 kV @ 5 kHz  
Fast Transient Disturbance IEC 61000-4-8 (2001), 1000 A/m for 3 seconds  
100 A/m for 1 minute  
IEC 61000-4-5 (2001), 2 kV line-to-line  
4 kV line-to-earth  
Electrostatic Discharge IEC 61000-4-3 (2002), 10 V/m  
ANSI/IEEE C37.90.2 (1995), 35 V/m  
IEC 61000-4-2 (2001), Levels 1, 2, 3, 4  
8 kV contact discharge  
15 kV air discharge  
IEC 61000-4-4 (2001), 4 kV @ 2.5 kHz and 2 kV @ 5 kHz  
Fast Transient Disturbance IEC 61000-4-8 (2001), 1000 A/m for 3 seconds  
100 A/m for 1 minute  
IEC 61000-4-5 (2001), 2 kV line-to-line  
4 kV line-to-earth  
Magnetic Field Immunity IEC 61000-4-8 (2001), 1000 A/m for 3 seconds  
100 A/m for 1 minute  
IEC 61000-4-5 (2001), 2 kV line-to-line  
4 kV line-to-earth  
Surge Immunity IEC 61000-4-8 (2001), 1000 A/m for 3 seconds  
100 A/m for 1 minute  
IEC 61000-4-5 (2001), 2 kV line-to-line  
4 kV line-to-earth

### Environmental

Cold IEC 60068-2-1 (1990), 16 hours @ -40°C  
Test Ad IEC 60068-2-2 (1993), 16 hours @ +85°C  
Dry Heat IEC 60068-2-2 (1993), 16 hours @ +85°C  
Test Bd IEC 60068-2-30 (1980), 25-50°C, 6 cycles, 95% RH  
Damp Heat, Cyclic IEC 60529 (2001), IP65, enclosed in panel; IP20 for terminals  
Test Ca IEC 60068-2-6 (1995), 10-150 Hz, 3G  
Enclosure Protection IEC 60255-21-2 (1988), 15G  
Vibration IEC 60255-21-2 (1988), 15G  
Test Fc, Severity Level IEC 60255-21-2 (1988), 15G  
Shock IEC 60255-21-2 (1988), 15G  
Severity Level IEC 60255-21-2 (1988), 15G

### Safety

Dielectric Strength IEC 60255-5 (2000), IEC 60947-4-1 (2001), IEC EN 60947-5-1 (1997)  
IEEE C37.90-1989, 2000 Vac on control inputs, contact outputs, and analog inputs; 2830 Vdc on power supply; 2500 Vac on ac current inputs; 1000 Vac on PTC and analog output.

## Certifications

Emissions: EN 50263: (1999)  
IEC EN 60947-4-1 (2001), IEC EN 60947-5-1 (1997)  
ISO: Relay is designed and manufactured using ISO 9001 certified quality program.  
Product Safety: IEC 61010  
UL 508, 1053  
CSA C22.2, No. 14

## Processing Specifications

### AC Voltage and Current Inputs

16 samples per cycle, 3 dB low-pass analog filter cut-off frequency of 560 Hz, ±5%

### Digital Filtering

Full-cycle cosine after low-pass analog filtering

### Protection and Control Processing

Four times per power system cycle

# SEL-749M

## Motor Protection Relay

### Ordering Options

#### ■ Firmware

Standard SEL-749M firmware with standard communications protocol (EIA-232 front and EIA-232 rear)

#### ■ Power Supply and I/O

125 Vdc or Vac, 250 Vdc or Vac, 3 contact outputs, and 2 optoisolated control inputs

24 Vdc or Vac, 48 Vdc or Vac, 3 contact outputs, and 2 optoisolated control inputs

Control input voltages (choose one): 24, 48, 110, 120, 220, and 250 Vac/Vdc

#### ■ Secondary Input Current

1 A phase or 5 A phase

1 A neutral or 5 A neutral

#### ■ IRIG-B/PTC Input

IRIG-B time-code (demodulated) input

PTC (Positive Temperature Coefficient) thermistor input (no IRIG-B time-code)

#### ■ Communications Protocol

Standard plus Modbus RTU EIA-485/232 (EIA-232 front and rear; EIA-485/232 card rear)

Standard plus DeviceNet (EIA-232 front and rear; CAN network interface rear)

#### ■ I/O Expansion

Four additional contact outputs, three additional optoisolated control inputs, one 4-20 mA output

Control input voltages (choose one): 24, 48, 110, 120, 220, and 250 Vac/Vdc

#### ■ Voltage Inputs

Wye-connected  $V_a$ ,  $V_b$ , and  $V_c$  or delta-connected  $V_{ab}$  and  $V_{bc}$  (300 Vac maximum)

### Commitment to Quality

Schweitzer Engineering Laboratories, Inc. is committed to quality. Our certification to the ISO 9001 quality standard and our ten-year product warranty are examples of this commitment. We encourage and appreciate your feedback about the use of SEL equipment, and we will use this information to continually improve our products and services.



### Contact Us

SEL sales representatives are prepared to assist you. Contact your nearest sales representative, application engineer, or customer service representative at (509) 332-1890. Visit our web sites at [www.selinc.com](http://www.selinc.com) or [www.selindustrial.com](http://www.selindustrial.com) for more information.

Copyright © SEL 2004 (All rights reserved). Printed in USA. All trademarks are the property of their respective holders. U.S. Patents 5208545, 5317472, 5436784, 6639413 and other patents pending. 749M1yr 20040501 • PF00059

### AC Motor Protection

By Stanley E. Zocholl  
Schweitzer Engineering Laboratories, Inc.

AC motors, induction or synchronous, are used extensively throughout the world in industrial, commercial, and utility applications. AC motors are vital components in many processes and require specific thermal and fault protection during overload and locked-rotor conditions.

*AC MOTOR PROTECTION* is a reference book written for professionals concerned with the operation and protection of ac motors.

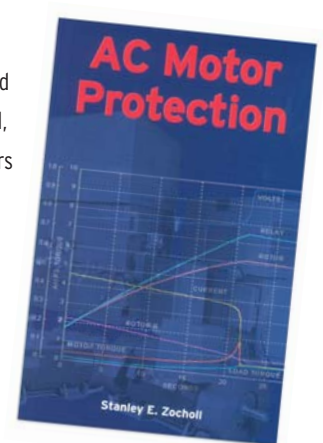

Visit [www.selinc.com/zocholl/index.html](http://www.selinc.com/zocholl/index.html) for more information and to purchase *AC Motor Protection*.



2350 NE Hopkins Court • Pullman, WA 99163-5603 USA  
Phone: (509) 332-1890 • Fax: (509) 332-7990 • E-mail: [info@selinc.com](mailto:info@selinc.com)  
Internet: [www.selinc.com](http://www.selinc.com) • [www.selindustrial.com](http://www.selindustrial.com)

***Making Electric Power Safer, More Reliable, and More Economical***