

SEL-787 Transformer Protection Relay

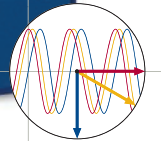

SEL Synchrophasors

SEL Advances the State of the Art in Transformer Protection

- **Synchrophasors** detect system oscillations and potential instability.
- **MIRRORED BITS® communications** is ideal for teleprotection and remote control applications.
- **Flexible communications** make control integration fast and easy.
- **Small form factor** speeds new installations and retrofits of electromechanical relays.
- **Commissioning Assistant** is the first transformer relaying software that recommends correction settings after identifying errors.

Optimize the Life of Your Transformers by Monitoring Key Health Indicators

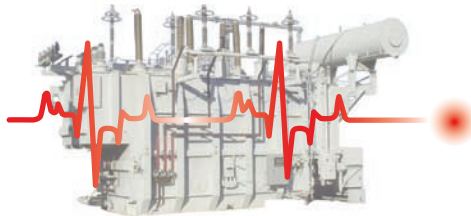

*Cumulative Through-Fault Current Recording
Measurement and Logic Input*

Flexible Communications

*Single or Dual
Copper or Fiber
Ethernet Port*

Three or Four
Serial Ports*

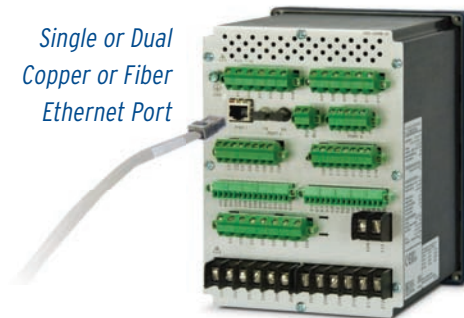

*Optional

Use Commissioning Assistant to Easily Generate Differential Compensation Settings

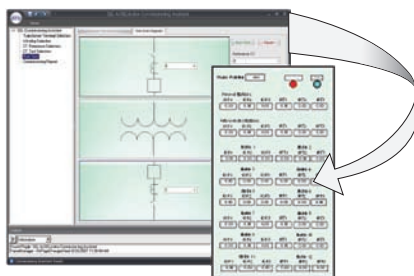

Industry-Leading Quality, Reliability, and Customer Service



Making Electric Power Safer, More Reliable, and More Economical®

Functional Overview

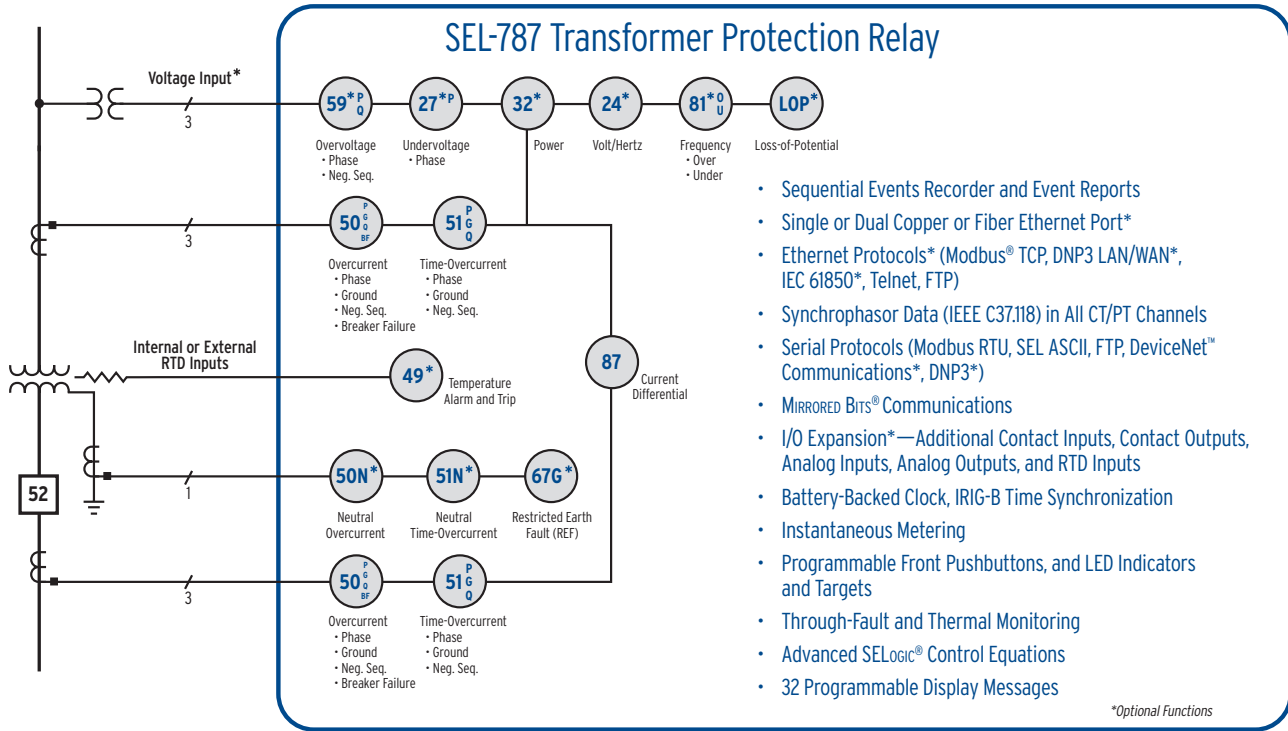

Feature Overview

Power supply options include:

24–48 Vdc
110–250 Vdc
110–230 Vac

Modbus TCP, Telnet, and FTP, with optional IEC 61850 and DNP3 LAN/WAN.

Single or dual copper or fiber Ethernet port.

Positions for optional expansion cards.

Two-winding CT inputs.

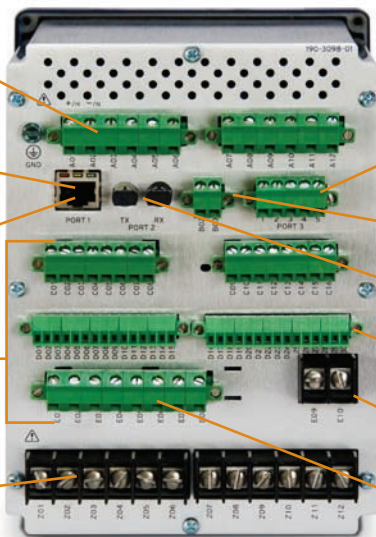

Ordering Options

- CPU Board
 - Single or dual copper or fiber Ethernet port
 - EIA-232 or EIA-485 rear port
 - IRIG-B input
- Optional Expansion Cards
 - 3 digital inputs/4 digital outputs/4–20 mA analog output
 - 4 digital inputs/4 digital outputs (electromechanical)
 - 4 digital inputs/4 digital outputs (fast, high-current interrupting)
 - 4 analog inputs/4 analog outputs
 - EIA-232 or EIA-485 serial communication
 - EIA-485 DeviceNet communication
 - 8 digital inputs
 - 10 RTD inputs
 - Neutral ac current input
 - Neutral ac current input/three-phase ac voltage (300 Vac) input
- Conformal Coating



Pullman, Washington USA
Tel: +1.509.332.1890 • Fax: +1.509.332.7990 • www.selinc.com • info@selinc.com

© 2007, 2008 by Schweitzer Engineering Laboratories, Inc. PF00167 • 20080616

